

PL-400

WE, WB
WP, S
S/G

OPERATING INSTRUCTIONS



Thank you for buying this Pioneer stereo turntable.

Please read through these operating instructions and then you will know how to operate your model properly. After you have finished reading the instructions, put them away in a safe place for future reference. These operating instructions are based on the model WE and they can be used for the WB, WP, S/G and S models. The differences between the models are given below.

Power Requirements

WE, WB, WP models: AC 220-240V ~, 50, 60Hz

S, S/G models: AC 110-120/220-240V ~
(switchable), 50, 60Hz

Note: (S, S/G models only)

Read through the section on the "LINE VOLTAGE SELECTOR SWITCH" before using your turntable and check that the voltage selector switch is set correctly for use in your area.

IMPORTANT

To prevent electric shock, do not remove cover. No user serviceable parts inside, refer servicing to qualified service personnel.

Always disconnect all the equipment from the mains supply when disconnecting the signal leads. The power cord should be connected last, make sure that the power switch is off.

Unplug the set from the wall socket when it is not to be used for an extended period of time.

FOR USE IN UNITED KINGDOM AND AUSTRALIA

CAUTION 240V: Mains supply voltage is factory adjusted at 240V.

FOR USE IN UNITED KINGDOM

The wires in this mains lead are coloured in accordance with the following cord:

Blue:	Neutral
Brown:	Live

As the colours of the wires in the mains lead of this apparatus may not correspond with the coloured marking identifying the terminals in your plug proceed as follow

The wire which is coloured blue must be connected to the terminal which is marked with the letter N or coloured black.

The wire which is coloured brown must be connected to the terminal which is marked with the letter L or coloured red.

CONTENTS

Assembly Procedure	2
Installation Precautions	3
Adjusting the Tonearm	4
Connections to Stereo Amplifier	5
Panel Facilities	6
Operation	8
Adjusting the Stylus Descent Position	10
Maintenance	10
Troubleshooting	11
Specifications	12
Line Voltage Selector Switch	12

ASSEMBLY PROCEDURE

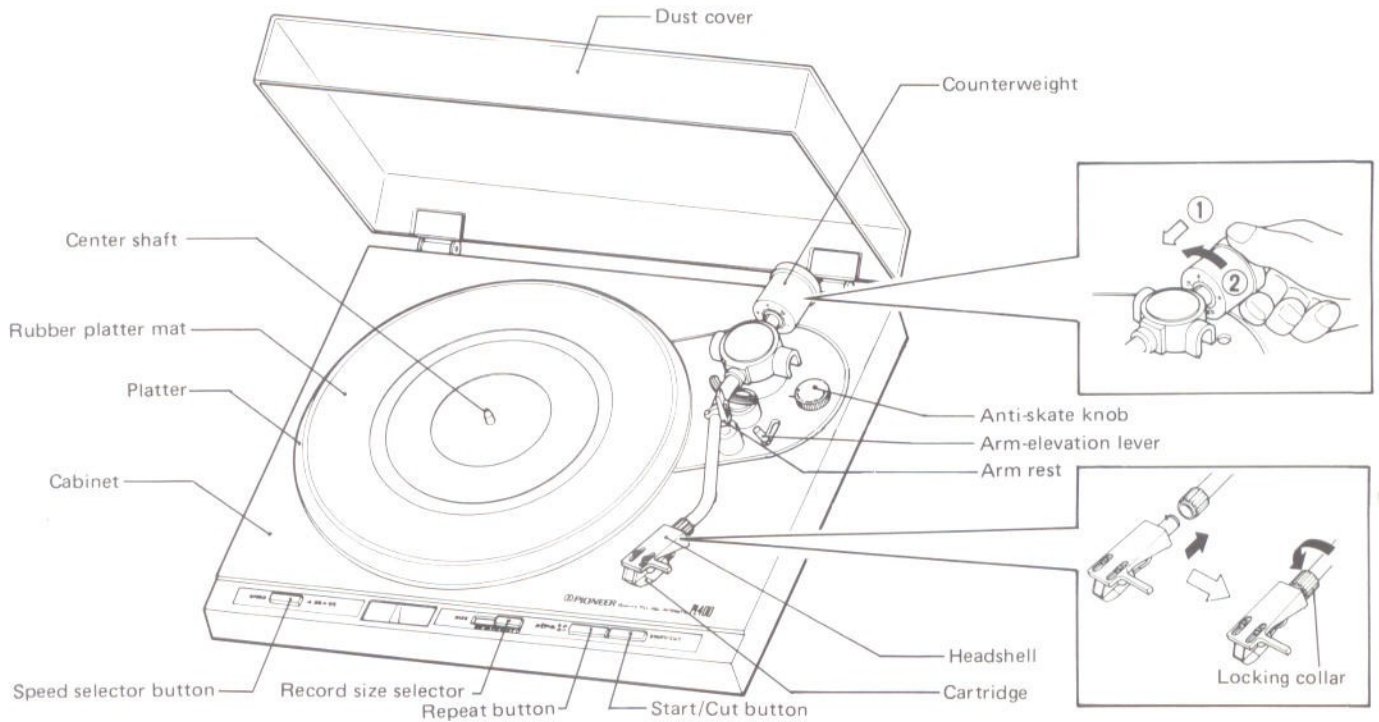

1. CHECK THE ACCESSORIES

The styrene pad contains the parts shown in the figure. Check that they are all inside. The EP adapter is used for records with a large center hole.

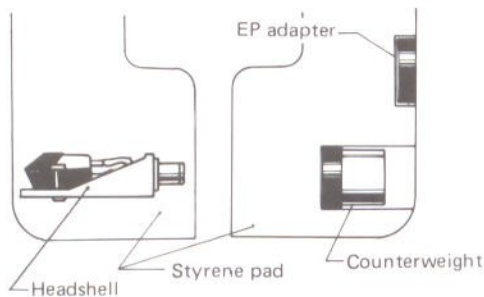

2. REMOVING TRANSIT SCREWS

Remove three transit screws with a Phillips screwdriver as shown below. Then remove platter and three platter pads.

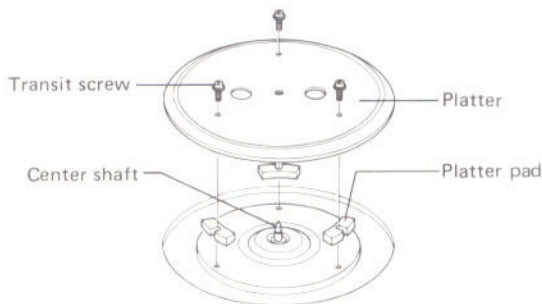

3. REMOVING DUST COVER

1. Fully open the dust cover.
2. Hold the dust cover, and lift it off by pulling it straight upward.

4. MOUNTING THE PLOTTER AND RUBBER PLOTTER MAT

Refer to the assembly figure, and place both the platter and the rubber platter mat down over the center shaft. The platter is heavy, so use both hands to lift it horizontally over the shaft and into position.

5. MOUNTING THE HEADSHELL

Insert the headshell (with the cartridge) into the end of the tonearm, and rotate the locking collar in the direction indicated by the arrow in the figure until it stops. Then secure it.

6. MOUNTING THE COUNTERWEIGHT

Slide the counterweight onto the counterweight shaft on the rear of the tonearm and push it forward. Then rotate it two or three turns in the direction of the arrow.

7. MOUNTING THE DUST COVER

To install, insert the hinges of the dust cover into the hinge sockets of the cabinet, and push the dust cover downward.

WHEN ANOTHER CARTRIDGE IS USED

There are many different kinds of cartridge available today. You can attach any cartridge weighing between 4g and 9g to this tonearm provided that only the accessory headshell is used with it. Follow the instructions with each cartridge regarding connection and use. When another cartridge is to be used in the headshell supplied with this turntable, install the cartridge very carefully, as follows:

1. Remove the headshell from the tonearm, and remove the screws that hold the accessory PC-150 cartridge in place.

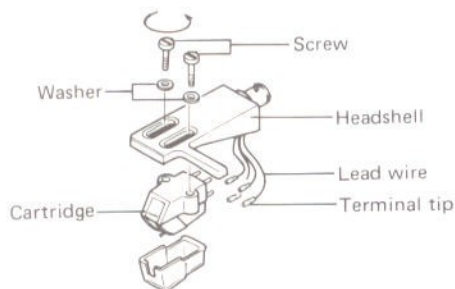

2. Remove the four lead wires from the cartridge itself. To protect the lead wires at this point, remove the terminal tips with pliers or the tip of the screwdriver.

3. The terminals on the accessory headshell are aligned according to the arrangement below. Check the location and polarity of each of the cartridge's terminal pins and then connect the lead wires, taking care not to get the polarities mixed up.

- Red: Right channel
- White: Left channel
- Green: Right channel ground
- Blue: Left channel ground

4. Attach the cartridge lightly to the headshell, using the screws, nuts, washers, etc.
5. Adjust the position of the cartridge so that the stylus and the connector section of the headshell are 49mm apart and tighten up the screws. Make sure that the cartridge does not tilt to one side when you attach it.

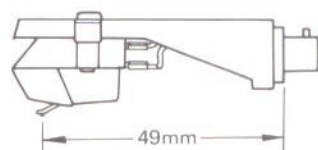

6. Attach the headshell to the tonearm.
7. Referring "ADJUSTING THE TONEARM" on page 4, re-adjust the tonearm with the new cartridge installed.

INSTALLATION PRECAUTIONS

When installing this turntable, make sure that you avoid the following conditions:

Conditions to be avoided	Possible problems caused
(1) Exposure to direct sunlight, high temperatures or high humidity.	(1) Can cause rust or interfere with insulation.
(2) Unstable surfaces.	(2) Will interfere with normal operation of turntable (stylus will jump, etc.).
(3) Dirty or dusty locations.	(3) Can cause scratches.
(4) Exposure to heavy vibrations, such as on the top of speakers.	(4) Can cause howl.
(5) Proximity to power transformer of the amplifier.	(5) Can cause hum.
(6) Locations where alcohol, insecticides, or flammable substances are frequently used.	(6) Can corrode dust cover or outside of cabinet.

If the turntable is brought into a warm room from previously cold surroundings, or if the room temperature rises suddenly, moisture will form on the operating sections and the turntable will not be able to display its performance to the full.

In a situation like this, leave the turntable in its new environment for about an hour, or try and increase the room temperature gradually, before operation.

ADJUSTING THE TONEARM

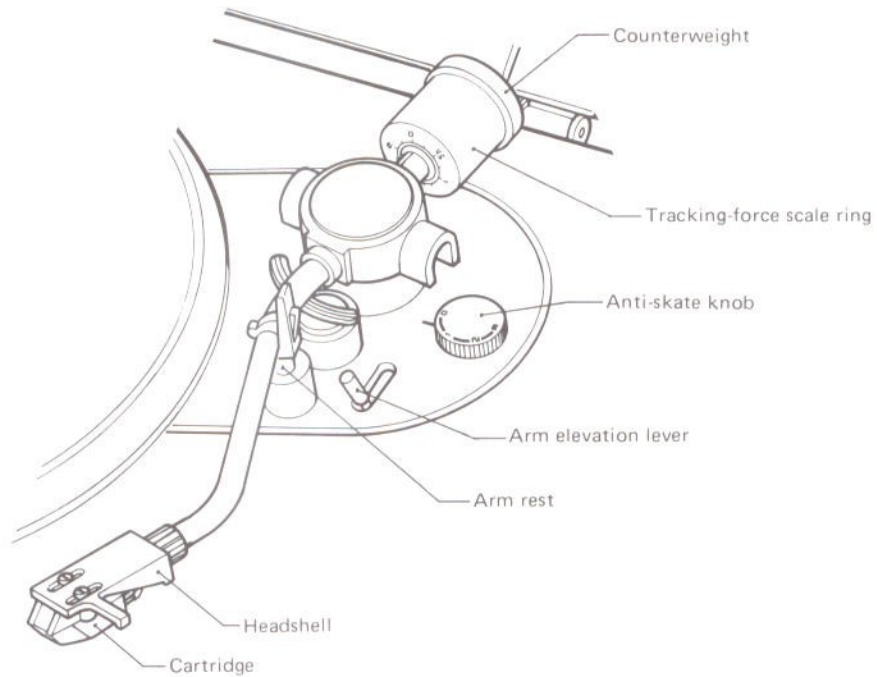

TRACKING FORCE ADJUSTMENT

1. Set the ANTI-SKATE knob to "0".

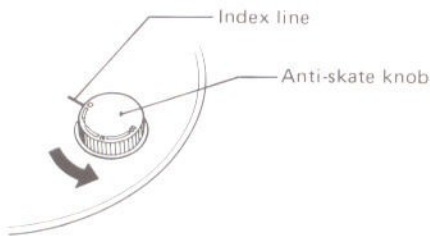

2. Remove the cartridge stylus cover.
3. Set the ARM-ELEVATION lever to the DOWN position.
4. Release the arm clamp and move the tonearm to the space between the arm rest and the platter, taking care not to damage the stylus.
5. Support the headshell's finger lift with one hand and attain the horizontal balance by turning the counterweight either clockwise or counterclockwise. "Horizontal balance" means that the tonearm is parallel to the record on the platter, and that the tonearm pipe, therefore, should not tilt toward the counterweight side or the headshell side (See figure).

Horizontally balanced state

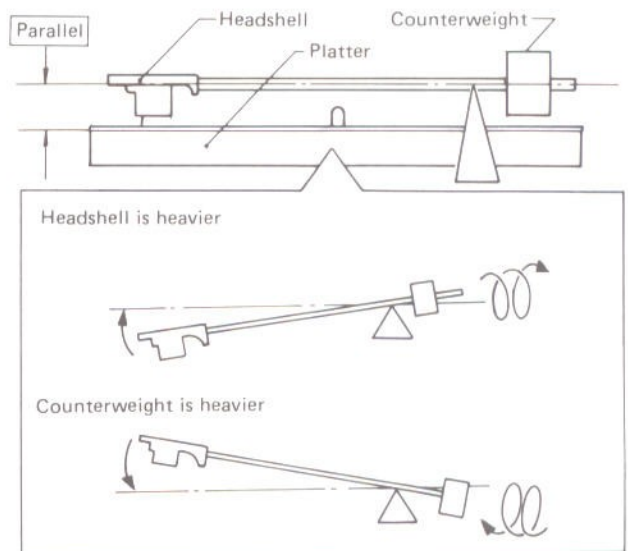

NOTE:

When the ANTI-SKATE knob is at the "0" position, the tonearm may move a little to the left or right. This is due to the enhanced sensitivity of the rotating section of the tonearm designed so that the tonearm traces the sound grooves on the record more efficiently during record play. This does not, therefore, interfere with play at all.

6. Return the tonearm to the arm rest and fasten the arm clamp.
7. Attach the stylus cover to protect the stylus.
8. Since the tracking force is zero when the tonearm is balanced horizontally, turn just the tracking-force scale ring in front of the counterweight, and set the "0" on the scale to the index line on the counterweight shaft (Fig. A).
9. While turning the counterweight, set so that the "2.2" comes to the index line on the counterweight shaft (Fig. B).

The tracking-force scale ring has 0.5g steps, and one full turn of the counterweight will yield a tracking force of 3g.

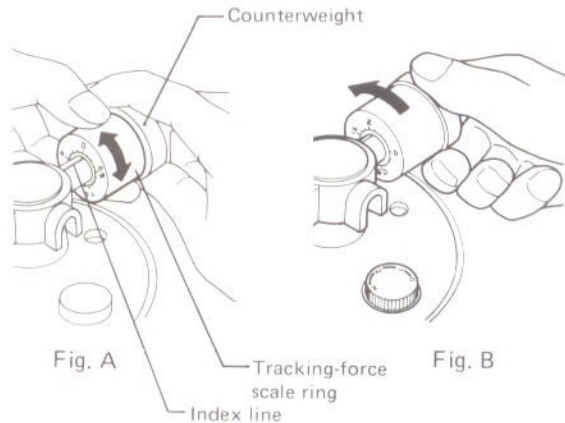

NOTE:

When playing records at low temperatures or when playing records where the stylus is made to jump or the reproduced sound is distorted (records where part of the recording level is set at an extremely high level), adjust the tracking force to the optimum value (this cartridge has 2.5g) across the suitable range.

ANTI-SKATING ADJUSTMENT

To adjust the anti-skating mechanism, turn the ANTI-SKATE knob so that the number corresponding to the required tracking force comes to the index line.

The numbers on the ANTI-SKATE knob correspond to the same number of the tracking force.

When the tracking force is set to 2.2 grams for the PC-150, set the "2.2" on the knob adjacent to the index line on the panel.

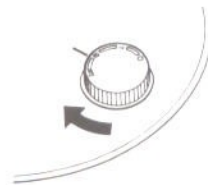

CONNECTIONS TO STEREO AMPLIFIER

BEFORE CONNECTING, CHECK THE FOLLOWING:

- Switch the power to the amplifier off to prevent damage to the speaker system.
- The cartridge furnished with your turntable is an MM type. Be sure to use a stereo amplifier which has PHONO input jacks for this type of cartridge.

NOTE:

If you are using a low-output moving coil (MC) cartridge, you will need a special MC transformer or a head amplifier, or a stereo amplifier with a built-in MC amplifier.

CONNECTION PROCEDURE

1. Insert the phono cables (white and red) into the PHONO input jacks of the stereo amplifier (white for left channel into L jack, and red for right channel into R jack).
2. Connect the ground lead with the Y-shaped connector at the end to the ground terminal.
3. Insert the power plug into the convenience AC outlet of the amplifier or a wall outlet.

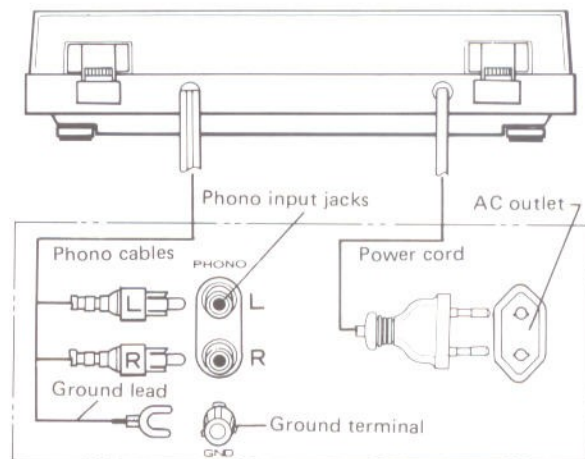

PANEL FACILITIES

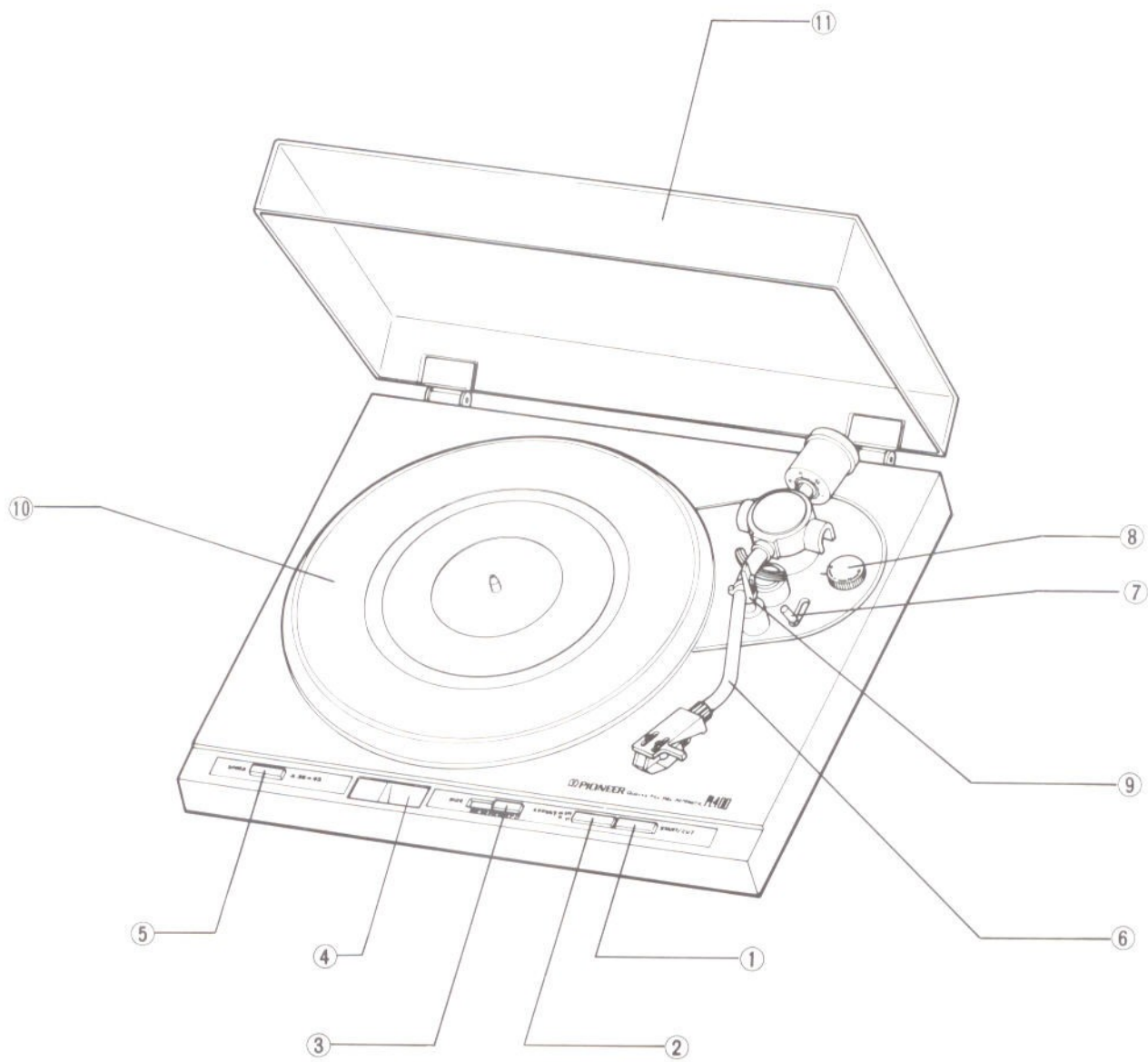

① START/CUT BUTTON

When this button is depressed, the power is turned on to the turntable, the strobe light comes on and the platter starts to rotate. With the RECORD SIZE SELECTOR set at one of the positions — 30, 25, or 17 — the tonearm moves automatically to the record disc as the platter starts rotating, thus starting record play (Refer to "AUTOMATIC PLAY" on page 8.)

If this button is depressed while the record is playing, the tonearm automatically returns to the arm rest, and the power to the turntable is cut off.

② REPEAT BUTTON

Push this button when you want to listen to the same record again. Press the button once more to release.

NOTE:

All you have to do for repeat play is to press the REPEAT button. There is no need to push the START/CUT button again.

③ RECORD SIZE SELECTOR

This selector selects the size of the record for automatic play.

7"17 For the automatic play of 17cm (7-inch) LP and EP records.

10"25 For the automatic play of 25cm (10-inch) LP records.

12"30 For the automatic play of 30cm (12-inch) LP records.

④ STROBE LIGHT

This light comes on when the tonearm moves away from the arm rest toward the platter. It irradiates the stroboscope around the outside of the platter.

⑤ SPEED SELECTOR BUTTON

45 When this button is depressed, the platter will rotate at 45rpm. Depress for playing 45rpm records, singles or EP's.

33 When this button is set to the release position, the platter will rotate at 33-1/3rpm. Release for playing 33-1/3rpm records like LP's.

⑥ TONEARM

This tonearm is designed to apply the correct tracking force to the cartridge and to keep this force at the precise level for faithful tracking of the record grooves. It also has the job of switching the power on to the turntable.

- When the tonearm is moved from the arm rest to the platter, the power comes on, the strobe lamp lights up, and the platter rotates.
- When the tonearm is returned to the arm rest, the power to the turntable is cut off, the strobe light goes off, and the platter stops rotating.

⑦ ARM-ELEVATION LEVER

UP (▲): When this lever is set to this position, the tonearm will rise. Set it to UP before record play and when you want to stop record play while a track is being played or when you want to change over to a different track.

DOWN (▼): When the lever is set to this position, the tonearm will be lowered. If it is set to DOWN for record play, the tonearm will be lowered onto the surface of the record, and play will begin.

⑧ ANTI-SKATE KNOB

This knob is used to cancel out the harmful skating force which is generated during record play.

For further details, see "ANTI-SKATING ADJUSTMENT".

⑨ ARM REST/CLAMPER

The arm rest supports the tonearm when it is not being used. Set the tonearm on its rest when it is not playing records. Clamp it into position if you don't have any immediate plans to play records.

⑩ PLATTER/RUBBER PLATTER MAT

When the tonearm is moved and power is supplied to the turntable, the platter will start rotating at the set rotation speed. The rubber platter mat stabilizes the records and also absorbs external vibration.

⑪ DUST COVER

Keep this closed unless operating the controls or tonearm, or changing over records. This serves to keep dust from adhering to the records during record play. When fully opened and pulled straight up, this dust cover can be removed from the cabinet.

OPERATION

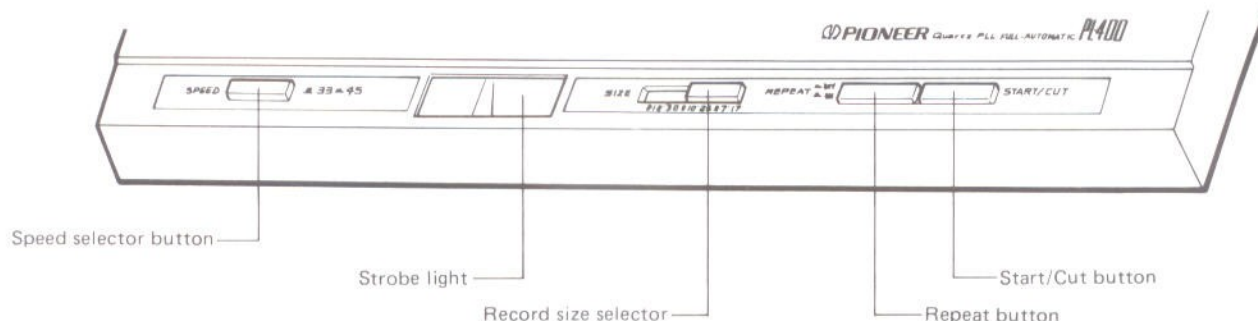

WHEN USING THE MODEL FOR THE FIRST TIME

When your model arrives, the vibrations sustained during transportation may have combined to make the auto mechanisms unstable. Make sure you proceed as follows when first using your model in order to make these mechanisms operate for correctly.

1. Set the arm elevation lever to the up position.
2. Move the tonearm from the arm rest to the platter. The platter will now start to rotate.
3. Depress the START/CUT button. The tonearm returns automatically to the arm rest from the platter, and the platter stops rotating.

AUTOMATIC PLAY

1. First, place the record on the platter.
2. Set the SPEED SELECTOR button to the speed at which the record is to be played.
3. Remove the stylus cover and release the arm clamp.
4. Set the ARM ELEVATION lever to the DOWN position.
5. Set the RECORD SIZE SELECTOR in accordance with the size of the record on the platter.
6. Press the START/CUT button slowly (until you hear the sound of the start mechanism being actuated). The strobe light comes on and the platter rotates. When the platter rotates, the tonearm moves, the stylus tip settles down gently onto the lead-in groove of the record, and play begins.
7. Adjust the volume and tone controls on the amplifier to the preferred levels, and then sit back and enjoy your record.
8. After the record has been played, the auto-return mechanism is actuated and the tonearm returns to the arm res. At the same time, the platter stops rotating and the power to the turntable is turned off.

9. Secure the tonearm to the arm rest with the clamp and attach the stylus cover to protect the stylus.

MANUAL PLAY

1. Place the record on the platter.
2. Set the SPEED SELECTOR button to the speed at which the record is to be played.
3. Remove the stylus cover and release the arm clamp.
4. Set the ARM ELEVATION lever to the UP position.
5. Hold the headshell by the finger lift and move the stylus across the record to the track you want played.
6. Set the ARM ELEVATION lever to the DOWN position. The stylus will descend slowly to the record and play will begin.
7. Adjust the volume and tone controls on the amplifier to the preferred levels, and then sit back and enjoy your record.
8. After the record has been played, the auto-return mechanism is actuated and the tonearm returns to the arm res. At the same time, the platter stops rotating and the power to the turntable is turned off.
9. Secure the tonearm to the arm rest with the clamp and attach the stylus cover to protect the stylus.

REPEAT PLAY

Proceed as follows if you want to listen to the same record again and again:

1. Press the REPEAT button.
2. Press the START/CUT button and play will begin.
3. After the record has been played, the auto-return mechanism is actuated, and the tonearm returns to the arm rest. A few seconds later the tonearm moves over to the record again, and play begins.

RELEASING REPEAT-PLAY MECHANISM

The repeat mechanism is released only when you push the REPEAT button during repeat play and then take your finger off the button. The turntable is then set to the normal auto play mode.

STOPPING RECORD PLAY

Press the START/CUT button gently (until you hear the sound of the return mechanism being actuated). The stylus will rise slowly from the surface of the record and the tonearm will return to the arm rest. The power to the turntable is turned off.

NOTE:

If you push the START/CUT button during repeat play, the tonearm will return to the arm rest and back again to the record for repeat play.

OPERATION PRECAUTIONS

- Always clean the stylus both before and after playing a record with a soft brush and make it a rule to clean the records with a good quality cleaner.
- When changing over the headshell, clamp the tonearm to the arm rest so that the tonearm shaft is not strained in any way.
- Be careful not to make the turntable vibrate while a record is playing since this can result in damage to the stylus and record.
- Place only one record at a time on the platter. If two or more records are stacked on the platter, the stylus will not make proper contact with the grooves, and this will impair the quality of reproduction.
- Do not disconnect the power cord while the stylus is still in a record groove as this may damage the stylus and record.
- Never obstruct the platter with the hand while it is rotating. This may cause damage.

ADJUSTING THE STYLUS DESCENT POSITION

If the stylus does not descend onto the lead-in groove on the record during automatic play, adjust as follows:

1. Place a 30cm (12-inch) LP record on the platter.
2. Go through the operation for automatic play once (refer to page 8), and check the level and direction of the stylus' deviation from the norm.
3. Return the tonearm to the arm rest with one hand, and then adjust the stylus descent-position by turning the adjusting screw in the adjusting hole using the screwdriver.
 - When the stylus descends outside the lead-in groove, turn the adjusting screw clockwise.
 - When the stylus descends inside the lead-in groove, turn the adjusting screw counterclockwise.
 - Each half-turn of the adjusting screw moves the starting point about 18 mm.

NOTE:

Be very careful not to damage the record and the stylus when you are adjusting the position of the stylus descent.

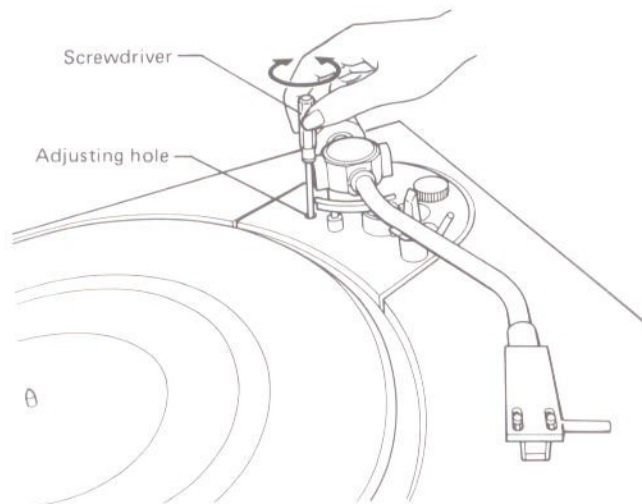

Stylus descends outside the groove

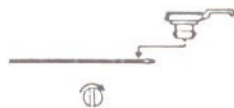

Stylus descends inside the groove



MAINTENANCE

CABINET AND DUST COVER

When the cabinet or dust cover becomes dusty or dirty, wipe it clean with a soft dry cloth. Remember that the surfaces can be corroded by furniture wax, thinner, and benzine and also by insecticide sprays. The dust cover can be detached and cleaned.

LUBRICATION

The motor shaft and bearings of this turntable employ oil-less bearings and so there is no need for lubrication. There is no need to lubricate the tonearm bearings, either.

STYLUS

If the stylus tip is clogged with dust, the reproduced sound quality will be impaired. Use a soft brush to keep the stylus clean at all times. Be careful not to touch the tip since this may damage it. When using stylus cleaner (organic solvent), benzine or thinner to clean the stylus tip, take care not to allow any of the liquid to come into contact with the stylus holder. This may change the material.

PC-150 STYLUS REPLACEMENT

The life expectancy of the PC-150 stylus tip is 800 ~ 1,000 hours. For the sake of maximum sound quality reproduction, Pioneer recommends replacement within the minimum time limit. The stylus tip is replaced by grasping the stylus holder and pulling it away from the body of the cartridge. The new stylus tip is then inserted by pushing it into the receptacle. The correct replacement tip is the PN-150. This may be obtained at your Pioneer dealer. Pioneer cannot guarantee performance or reliability if another type of stylus is employed.

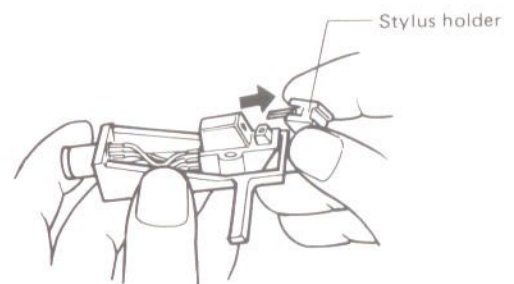

TROUBLESHOOTING

Sometimes, an operational fault can be mistaken for a malfunction or failure. Check the following points and see if you can find the symptoms of the trouble below before you get in touch with the serviceman. If you cannot locate the symptoms, contact your nearest Pioneer dealer.

Symptom	Possible trouble	Remedy
Platter does not rotate.	Power cord is unplugged.	Plug cord securely into wall outlet.
No sound	<ol style="list-style-type: none"> 1. Phono cables are not connected properly. 2. Headshell is not properly attached. 3. Cartridge lead wires are loose. 4. Amplifier is not being operated properly. (Function switch, tape monitor switch, speaker switches, etc. are not set correctly). 	<ol style="list-style-type: none"> 1. Connect cables securely to the PHONO input jacks on the amplifier (see page 5). 2. Firmly secure tonearm locking collar (see page 2). 3. Attach lead wires inside headshell properly (see page 3). 4. Read the operating instructions that come with amplifier.
Excessive noise.	<ol style="list-style-type: none"> 1. Ground lead is not connected. 2. Tracking force is not correct. 3. Dust or dirt has collected on the stylus tip. 4. Dust or dirt has collected on the record. 	<ol style="list-style-type: none"> 1. Connect properly to the amplifier's ground terminal (see page 5). 2. Refer to tracking force adjustment on page 4. 3. Clean the stylus tip with a soft brush. 4. Clean the record with a good quality cleaner.
Sound is distorted.	<ol style="list-style-type: none"> 1. Dust or dirt has collected on the stylus tip. 2. Tracking force is not correct. 3. Stylus is worn. 4. Amplifier's tone controls set too high. 	<ol style="list-style-type: none"> 1. Clean the stylus tip with a soft brush. 2. Refer to tracking force adjustment on page 4. 3. Replace with new stylus. 4. Set tone controls to lower position.
Tonearm does not descend with auto play.	<ol style="list-style-type: none"> 1. ARM ELEVATION lever is set to UP position. 2. Tracking force is not correct. 	<ol style="list-style-type: none"> 1. Set to DOWN position. 2. Refer to tracking force adjustment on page 4.
Tonearm does not move with auto play.	Arm clamp is still fastened.	Release arm clamp.
Intermittent sound.	<ol style="list-style-type: none"> 1. Tracking force is not correct. 2. Stylus is worn. 3. Record is scratched or warped. 	<ol style="list-style-type: none"> 1. Refer to tracking force adjustment on page 4. 2. Replace with new stylus. 3. Replace record.
Stylus does not descend to correct position with auto-play.		See stylus descent-position adjustment on page 10.
<p>If you detect any trouble when playing records, the fault may not lie with the turntable but with another hi-fi component. Be sure to check the amplifier, speaker system, and any other electrical equipment which you are using in the vicinity of the turntable.</p>		

SPECIFICATIONS

Motor and Turntable

Drive System	Direct-drive
Motor	Quartz PLL Hall motor
Turntable Platter	310mm diam. aluminum alloy die-cast
Moment of Inertia	180kg-cm ² (including platter mat)
Speeds	33-1/3 and 45rpm
Wow and Flutter	Less than 0.025% (WRMS)
Signal-to-Noise Ratio	More than 75dB (DIN-B)
	(with Pioneer cartridge model PC-150)

Rotational Characteristics

Build-up Time	Within 120° rotation at 33-1/3rpm
Speed Deviation	Less than 0.002%
Speed Drift	Less than 0.00008%/h at 33-1/3rpm
	Less than 0.00003%/degree temp. change at 33-1/3rpm

Tonearm

Type	Static-balance type, S-shaped pipe arm
Effective Arm Length	221mm
Overhang	15.5mm
Usable Cartridge Weight	4g (min.) to 9g (max.)

Subfunctions

Full auto mechanism, Anti-skating force control, Stylus pressure direct-readout counterweight, Cueing device, Strobe light, Free stop hinges

Semiconductors

ICs	3
-----	---

Transistors	3
Diodes	6
Hall Elements	3

Miscellaneous

Power Requirements:

WE, WB, WP models	220 - 240V ~, 50, 60Hz
S, S/G models	AC110-120/220-240V ~ (switchable), 50, 60Hz

Power Consumption8W

Dimensions420(W) x 96(H) x 365(D)mm
16-1/2(W) x 3-13/16(H) x 14-3/8(D)in.

Weight6.5kg/14 lb 5 oz.

PC-150 Specifications

Type	Moving magnet type
Stylus	0.5 mil diamond (PN-150)
Output Voltage	3.5mV (1kHz, 50mm/s Peak velocity, LAT)
Tracking Force	1.7g to 2.5g (proper 2.2g)
Frequency Response	15 to 30,000Hz
Recommended Load	50kΩ +170 ~ 300pF

Accessories

EP Adapter	1
Operating Instructions (French and German furnished on models for WE)	1

NOTE:

Specifications and design subject to possible modification without notice, due to improvements.

LINE VOLTAGE SELECTOR SWITCH

The line voltage selector switch is located on the top surface of the cabinet of this turntable. Before your turntable is shipped from the factory, the switch is set to the power requirements of the turntable's destination, check that it is set properly before plugging the power cord into the outlet. If the voltage is not properly set or if you move to an area where the voltage requirements differ, adjust the selector switch as follows:

1. Disconnect the power cord.
2. Provide yourself with a medium-sized screwdriver. Insert the tip of the screwdriver into the groove of the selector switch and turn it so that the power voltage marking of your area points to the white mark.

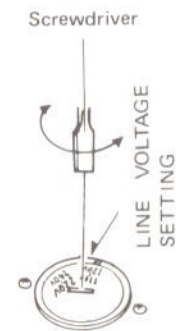

S and S/G model

PIONEER ELECTRONIC CORPORATION 4-1, Meguro 1-Chome, Meguro-ku, Tokyo 153, Japan
U.S. PIONEER ELECTRONICS CORPORATION 85 Oxford Drive, Moonachie, New Jersey 07074, U.S.A.
PIONEER ELECTRONIC (EUROPE) N.V. Luithagen-Haven 9, 2030 Antwerp, Belgium
PIONEER ELECTRONICS AUSTRALIA PTY. LTD. 178-184 Boundary Road, Braeside, Victoria 3195, Australia